

DIE GRINDER

Collet Size 6mm

- Low speed and high torque. ● Lever type. ● Urethane covered cushion grip.
- Built-in power regulator. ● 360 degree rotating rear exhaust.

SP-7203



Option
● #02000241 3 mm Collet chuck

Collet Size 6mm

- Safety lever. ● Urethane covered cushion grip. ● Built-in power regulator.
- 360 degree rotating rear exhaust port.

SP-7200



Option
● #02000241 3 mm Collet chuck

Collet Size 6mm

- 90 degree corner type. ● Safety lever. ● Urethane covered cushion grip.
- Built-in power regulator. ● 360 degree rotating rear exhaust.

SP-7201



Option
● #02000241 3 mm Collet chuck
● #05202111 50 mm Pad (Velcro)

Collet Size 6mm

[ROTATIONAL HEAD]

- 90 degree corner type. ● Rotating head (fixed at 90 degree each) ● Safety lever.
- Urethane covered cushion grip. ● Built-in power regulator. ● 360 degree rotating rear exhaust port.

SP-7201RH



Option
● #02000241 3 mm Collet chuck
● #05202111 50 mm Pad (Velcro)

Collet Size 6mm

- 120 degree corner type. ● Safety lever. ● Urethane covered cushion grip.
- Built-in power regulator. ● 360 degree rotating rear exhaust.

SP-7202



Option
● #02000241 3 mm Collet chuck
● #05202111 50 mm Pad (Velcro)

Collet Size 3mm

[ROTARY GRIP]

- Long tip type. ● Throttle switch for continuous operation.
- For finishing molds and deburring.

SP-6210GA

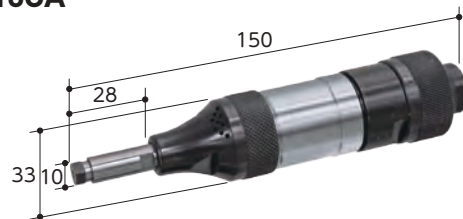

Collet Size 6mm

- Long tip type. ● Throttle switch for continuous operation.
- Max. dia. 25 mm (mounted wheel) ● Max. dia. 12.7 mm (carbide bar)

SP-6211GA

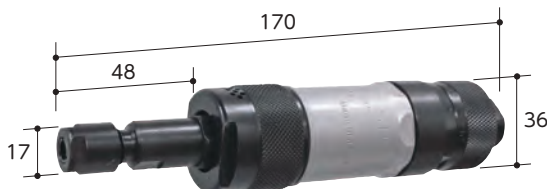

Collet Size 6mm

- High power. ● Throttle switch for continuous operation.
- Max. dia. 32 mm (Flap wheel). ● For finishing molds and deburring.

SP-6213GA



EDP	Model No.	Grip Dia. (mm)	Install method	Free Speed (min ⁻¹)	Overall Length (mm)	Air Consumption (m ³ /min)	Hose Coupling	Net Weight (kg)	Accessories	JAN (4545695)
370093	SP-7203	40	Collet Nut	5500	165	0.2	1/4"NPT	0.54	Spanner (H19mm, H14mm)	003708
370082	SP-7200	36	Collet Nut	23000	153	0.2	1/4"NPT	0.41	Spanner (H17mm, H11mm)	000332
370089	SP-7201	36	Collet Nut	20000	130	0.2	1/4"NPT	0.55	Spanner (H17mm, H11mm)	000349
370086	SP-7201RH	41	Collet Nut	20000	160	0.2	1/4"NPT	0.55	Spanner (H17mm, H11mm)	001643
370088	SP-7202	36	Collet Nut	20000	194	0.2	1/4"NPT	0.56	Spanner (H17mm, H11mm)	000356
370091	SP-6210GA	34	Collet Nut	30000	150	0.25	1/4"NPT	0.44	Spanner (H8mm), Open End Wrench (H8mm)	003265
370087	SP-6211GA	36	Collet Nut	24000	170	0.4	1/4"NPT	0.4	Spanner (H15mm, H14mm)	003272
370096	SP-6213GA	34	Collet Nut	18000	213	0.45	1/4"NPT	0.45	Spanner (H14mm, H12mm)	003296

Air pressure: 0.62 MPa Air hose inner dia.: 9.5mm (6mm:SP-6210GA), (8mm:SP-6211GA,SP-6213GA), (10mm:SP-6203GA) Rear exhaust, Front side exhaust (SP-6210GA, SP-6211GA, SP-6213GA) Air connector included

FASTENING

DRILLING

SANDING

GRINDING

CUTTING

HAMMERING

BEVELER

DIE GRINDER

Collet Size $\Phi 6\text{mm}$

- Lever type. ● Built-in power regulator.

SP-1200

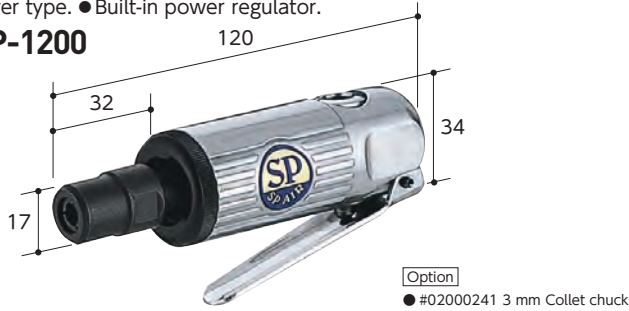

Collet Size $\Phi 6\text{mm}$

[90 degree]

- Low speed and high torque. ● Lever type. ● Built-in power regulator.

SP-1523

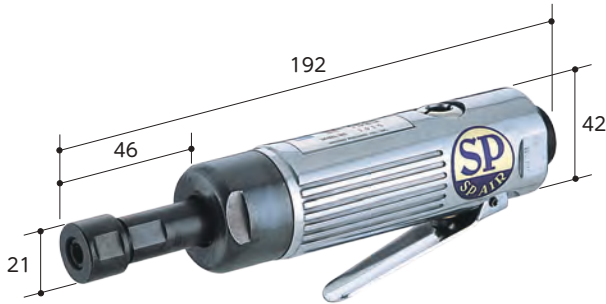

Collet Size $\Phi 6\text{mm}$

[90 degree]

- Lever type. ● Built-in power regulator.

SP-1220

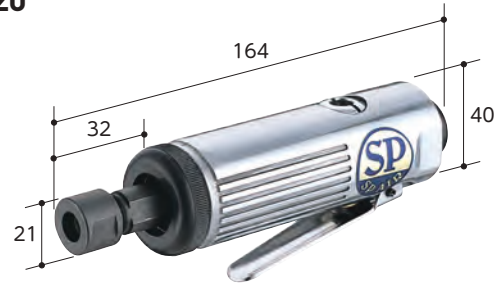

Collet Size $\Phi 6\text{mm}$

- 90 degree corner type ● Lever type. ● Built-in power regulator.

SP-1200AH



LONG DIE GRINDER

Collet Size $\Phi 6\text{mm}$

- Long type ● Throttle switch for continuous operation. ● For finishing the inside of pipes and deburring.

SP-6203GA

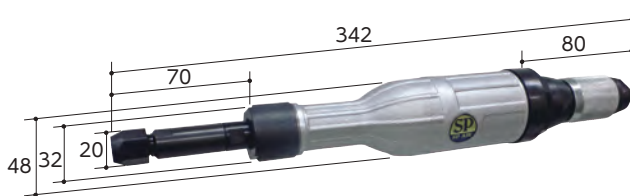

EDP	Model No.	Grip Dia. (mm)	Install Method	Free Speed (min ⁻¹)	Overall Length (mm)	Air Consumption (m ³ /min)	Hose Coupling	Net Weight (kg)	Accessories	JAN (4545695)
370085	SP-1200	34	Collet Nut	28000	120	0.2	1/4"NPT	0.3	Spanner (H17mm, H11mm)	000288
370094	SP-1220	40	Collet Nut	23000	164	0.4	1/4"NPT	0.56	Spanner (H19mm, H14mm)	000318
370090	SP-1523	42	Collet Nut	3800	192	0.4	1/4"NPT	0.72	Spanner (H19mm, H14mm)	000325
370084	SP-1200AH	34	Collet Nut	21000	125	0.2	1/4"NPT	0.45	Spanner (H17mm, H11mm)	000295
370092	SP-6203GA	48	Collet Nut	14600	342	0.55	3/8"NPT	1.26	Spanner (H17mm, H11mm)	003302

Air pressure: 0.62 MPa Air hose inner dia.: 9.5mm (10mm:SP-6203GA) Front exhaust (SP-1200, SP-1200AH), Rear exhaust (SP-1200, SP-1523), Side exhaust (SP-6203GA) Air connector included